

Fluitec Documentation Nr. 11.117 Rev. 1

Static mixer for turbulent flow **CSE-X/2[®], material PTFE lined**

The Fluitec Mixers CSE-X/2 and CSE-X/4 are manufactured according to DIN2632 in standard sizes of DN15 to DN300. They are used for very aggressive media in the chemical industry. Type «T» is especially suitable to mix highly viscous liquids.

Fields of application of the PTFE-mixer

The multitude of special solutions of the CSE-X/2 mixer enables a large field of application. PTFE-mixers are used for the following applications:

- to mix aggressive fluids
- to dissolve aggressive gases (FSB-reactor)
- for pH-neutralisation
- to control reactions
- as residence time reactor

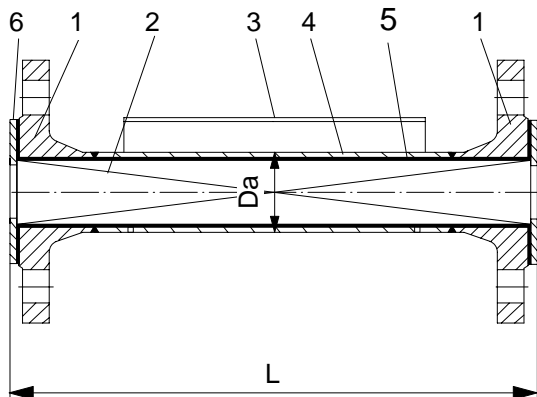

Fig. 1: Fluitec Mixer CSE-X/2 Type «T»

Description:

1. Flanges according to DIN 2632, pressure 10
2. CSE-X/2 mixing elements (PTFE or PVDF)
3. Identification plate
4. Pipe according to DIN 2463
5. PTFE lining
6. Intermediate flange plate of PTFE

Standard - Material:

- Housing R-St. 37-2 primed
- Lining PTFE ASTM D 4894-89/-a
- The temperature of 150°C should only be exceeded in accordance with the manufacturer.

Fluitec Mixer CSE-X/2 Typ «T» and «T-3»

For mixing of low viscous fluids the CSE-X/2 mixer type «T» is used. Characteristic is the constant length in different mixer concepts. The standard measurements are shown in Fig 1.

| DN | Da | L |
|-----|-------|------|
| (-) | (mm) | (mm) |
| 15 | 21.3 | 120 |
| 20 | 26.9 | 140 |
| 25 | 33.7 | 200 |
| 32 | 42.4 | 250 |
| 40 | 48.3 | 300 |
| 50 | 60.3 | 380 |
| 65 | 76.1 | 480 |
| 80 | 88.9 | 580 |
| 100 | 114.3 | 750 |
| 125 | 139.7 | 920 |
| 150 | 168.3 | 1100 |
| 200 | 219.1 | 1450 |
| 250 | 273 | 1820 |
| 300 | 323.9 | 2200 |

Fig. 2: Measurement of the CSE-X/2 Mixtures type «T»



Fig. 3: Fluitec Mixer CSE-X/2 Type «T»

Fluitec Mixer CSE-X/2 Type «T»

Mixing aqueous additives, the Fluitec Mixer CSE-X/2 type «T» can be used for flow ratios of up to 1:10⁰⁰⁰. Even for additives with a viscosity of 100 mPas, the mixer obtains a homogeneity of <1 to 5% at small pressure drop. Installation site and feeding technology should be discussed with the mixer specialist. On request, the Fluitec mixer CSE-X/2 type «T» can be produced with external feeding device. Simultaneous mixing of several additives with only one mixer is possible.

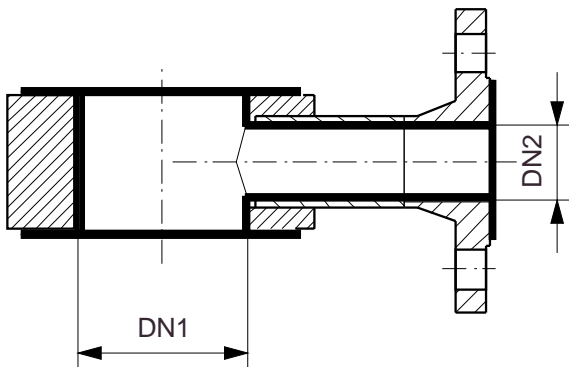

Fig. 4: Fluitec feeding device with PTFE lining

Fluitec Mixer CSE-X/2 type «T-3»

The Fluitec Mixer CSE-X/2 type «T-3» is used for difficult mixing tasks in turbulent flow applications. The additive flow can have a flow ratio of up to 1:10⁶. For mixing tasks with a viscosity ratio of up to 1:400, the CSE-X/2 mixer of the type «T-3» is proved, for years. At the same time, the mixer obtains a homogeneity of <1 to 5% at very small pressure drop. Installation site and feeding technology should be discussed with the mixer-specialist. Special construction, like the FSBR-reactors for aeration of fluids or the residence time reactor for the exact control of chemical reactions, are available on request.



Fig. 5: Fluitec CSE-X/2 Residence Time Reactor DN150

Pressure drop

The pressure drop of the Fluitec mixer CSE-X/2 type «T» is shown in the picture. The pressure drop changes proportionally to the density of the liquid. Using Figure 6, the pressure drop can be determined and converted for the medium of interest.

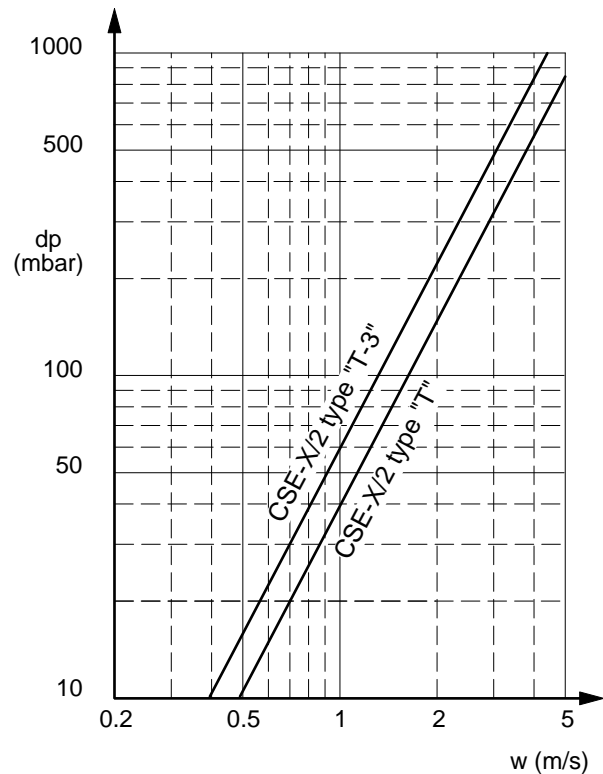

Fig. 6: Pressure drop of the Fluitec mixer for water.

Gasification reactor

Gasification of fluids with the FSBR-reactor succeeds in the chemical industry. Compared with other conventional static mixers, the FSB-reactor obtains up to 5 times higher $k_L a$ -values. The small bubbles are produced by a combination of sintered material and a static mixer. The unique construction enables the economical dosage of aggressive gases, even at high temperatures. Based on the low pressure drop and the extremely high efficiency, the FSB-reactor sets a new standard in in-line gasification. Fields of applications are described in other documentations.



Fig. 7: Fluitec Small Bubbles Reactor